

Dualit®

Since 1945



Burr Coffee Grinder

Instruction Manual & Guarantee

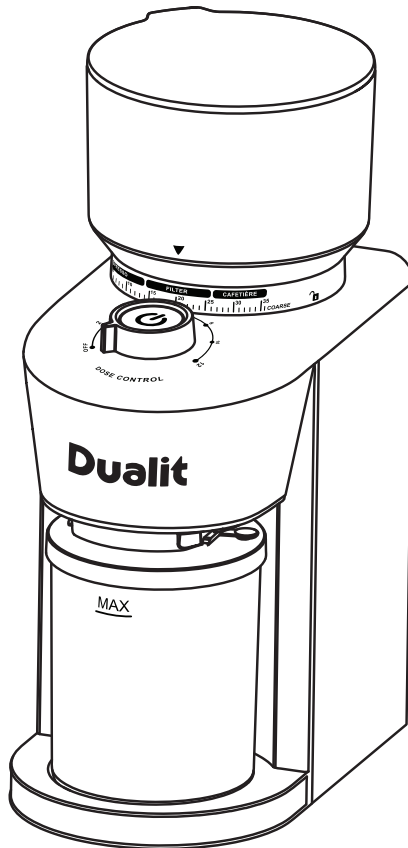

DON'T FORGET
TO **REGISTER**
YOUR PRODUCT

WWW.DUALIT.COM/REGISTER

OR BY POST



CONTENTS

Safety precautions _____	03
Know your Coffee Grinder _____	06
Setting up _____	07
Using your Coffee Grinder _____	08
Grinding for filter and cafetière coffee _____	09
Grind chart _____	10
Grinding for espresso coffee _____	10
Cleaning _____	11
Hints and tips _____	12
Quick start grind settings _____	13
Troubleshooting _____	15
Guarantee _____	16



IMPORTANT SAFETY PRECAUTIONS



READ ALL INSTRUCTIONS BEFORE USING THE APPLIANCE.

KEEP THESE INSTRUCTIONS FOR FUTURE REFERENCE.

IMPORTANT SAFEGUARDS

- **THIS IS AN ATTENDED APPLIANCE**
Do not leave appliance unattended during use, unplug after each use. Risk of fire if an unattended appliance is left operating or plugged in.
- This appliance must not be used by children younger than 8 years old and persons with very extensive and complex disabilities. Children aged 8-14 years and persons with reduced physical, sensory or mental capabilities or lack of experience and knowledge shall not use this appliance, unless they are supervised and have been given instruction concerning the use of the appliance in a safe way and understand the hazards involved. Close supervision is necessary when any appliance is used by or near children. Children shall be supervised to ensure that they do not play with the appliance. Cleaning and user maintenance shall not be made by children unless they are older than 8 and supervised. Keep the appliance and its cord out of reach of children less than 8 years old. **Risk of fire, electric shock, scalding or injury to persons.**
- This appliance is intended for household use only. If the appliance is used improperly or for professional or semi-professional purposes or if it is not used according to these instructions the Guarantee becomes invalid and Dualit refuses any liability for damage caused. **Risk of fire, electric shock, scalding or injury to persons.**

Electrical Safety

- **B**efore plugging in, check that the voltage on the rating label is the same as the mains supply. **Risk of electric shock and fire.**
- **N**ever plug an appliance into a socket/outlet with other appliances connected to it or a socket/outlet with additional features such as, but not limited to, USB sockets, built-in Wi-Fi boosters, remote Wi-Fi/Bluetooth or similar smart switching functionality. Failure to do this may cause an overload, trip a circuit breaker or blow a fuse. **Risk of electric shock and fire or damage to socket/outlet and plug.** The socket/outlet should be protected by a Residual Current Device (RCD).
- **S**witch off appliance, unplug and allow to cool before approaching or changing any attachment. **Risk of electric shock and injury to persons.**
- **A**lways disconnect the appliance from the supply if it is left unattended and before assembling, disassembling, approaching parts that move in use or cleaning. To unplug, grasp the plug and pull from the outlet. Never pull from the power cord. **Risk of electric shock and injury to persons.**
- **T**o be protected against electrical hazards, fire and injury to persons, do not immerse the power cord, plug or appliance in water or any other liquid. **Risk of electric shock.**
- **N**OTE: Any plug cut from the power supply cord should be disposed of immediately. Inserting any cut off plug into a socket-outlet is hazardous. **Risk of electric shock and fire.**
- **D**o not operate any appliance with a damaged lead or plug, or after the appliance malfunctions or has been dropped, damaged or cracked in any manner. **Risk of electric shock and fire.**
- **I**n order to avoid a hazard, if the Power Cord is damaged it must, for safety reasons, be replaced by Dualit or a qualified electrician. Call Dualit's Customer Helpline on +44 (0)1293 652 500. **Risk of electric shock and fire.**



IMPORTANT SAFETY PRECAUTIONS



- **N**ever use the plug without the fuse cover fitted. Ensure replacement fuse is the same current value as the original. Replacement fuses are available and should be ASTA approved to BS1362. **Risk of electric shock and fire.**
- **N**ever touch the Power Cord with wet hands. **Risk of electric shock.**
- **M**ake sure the cord or plug isn't in contact with anything hot or wet. **Risk of electric shock.**
- **D**o not allow cable to touch hot surfaces, or to hang over edge of a table or counter top. **Risk of fire or electric shock.**
- **T**he use of extension cables not authorised by the manufacturer may cause damage or accidents. **Risk of electric shock.**
- **D**o not use appliance for any purpose other than the intended use. **Risk of fire, electric shock, scalding or injury to persons.**
- **D**o not use scouring pads or abrasive cleaner on the appliance body. **Risk of damage.**
- **T**he Burrs are extremely sharp; take extra care when handling these parts, especially when removing from the main body during cleaning. Avoid touching the sharp parts. **Risk of injury.**
- **N**ever operate the appliance with an empty Hopper. **Risk of damage.**
- **D**o not misuse the appliance; it is designed for use with roasted coffee beans only. **Risk of fire, electric shock or injury to persons.**
- **B**efore each use, check that the Hopper contains coffee beans only and nothing else. **Risk of fire, electric shock or injury to persons.**
- **E**nsure that the Bean Hopper is securely in place before switching the appliance on. The Grinder will not work without the Hopper locked in place. **Risk of injury.**
- **N**ever remove the Hopper or Hopper Lid until the Burrs have come to a complete stop and you have switched off the power. **Risk of injury and electric shock.**
- **N**ever touch moving parts or insert your hand or any utensils into the Hopper. **Risk of injury and electric shock.**
- **T**o prevent clogging and overheating of the motor, never grind above the 'MAX' line of the Grind Container. **Risk of damage.**
- **T**o prevent overheating, do not grind for more than three minutes within any 10 minute period. If you exceed three minutes, the grinder will stop: unplug the machine and leave to cool for 30 minutes, before plugging back in and resuming grinding.
- **U**nless explicitly stated in the cleaning section of these instructions, never put the appliance or part of it in a dishwasher. **Risk of damage and electric shock.**
- **A**ccessible surfaces of the toaster may get hot during use. Therefore use handles or knobs. **Risk of burns.**
- **W**hen moving the appliance, use both hands and lift holding the base unit. Never lift the appliance using the Bean Hopper. **Risk of damage and injury to persons.**

General Safety

- **D**o not attempt to defeat or override the safety interlock mechanisms. **Risk of damage and injury to persons.**
- **I**f the Grinder is jammed, switch off immediately and unplug the appliance before removing the Hopper. **Risk of damage and injury to persons.**
- **T**he use of accessory attachments not recommended by Dualit may result in **fire, electric shock or injury to persons.**
- **D**o not place on a tray or surface that may collect liquid. **Risk of electric shock.**
- **R**emove all packaging before use. **Risk of fire.**
- **D**o not use in bathroom or outdoors. **Risk of electric shock.**
- **D**o not operate on an uneven surface. The appliance must only be operated on a flat, horizontal surface. **Risk of injury.**
- **T**he appliance shall not be placed in a cabinet or appliance garage when in use **Risk of fire.**



Accessible surfaces of the toaster may get hot during use. Therefore use handles or knobs. **Risk of burns.**

SAVE THESE INSTRUCTIONS

*In the interest of improving products, Dualit Ltd reserves the right to change the product specification without prior notice.
All illustrations are for representation only, your model may vary from illustrations shown.*



INSTRUCTIONS ON ENVIRONMENT PROTECTION

Do not dispose of this product in the usual household garbage at the end of its life cycle. Please hand it over to a collection point for the recycling of electrical and electronic appliances. The symbol on the product, the instruction of use or the packaging will inform you about the methods of disposal. The materials are recyclable as mentioned on its marking. By recycling, material recycling or other forms of re-utilization of old appliances you are making an important contribution to protect our environment. Please enquire about the community administration for the authorised disposal location.

IMPORTANT: BEFORE FIRST USE

- **R**ead this instruction manual before you start using the appliance. It gives you important safety information and will ensure you get the most out of your Dualit product.
- **K**eeep this manual and your proof of purchase in a safe place
- **D**on't forget to register your product at www.dualit.com/register
- **U**npack the box with care, keeping all the packaging materials until you are satisfied everything is present and in working order. Once satisfied recycle the packaging appropriately.

DON'T FORGET TO REGISTER YOUR PRODUCT

WWW.DUALIT.COM/REGISTER

OR BY POST



KNOW YOUR COFFEE GRINDER

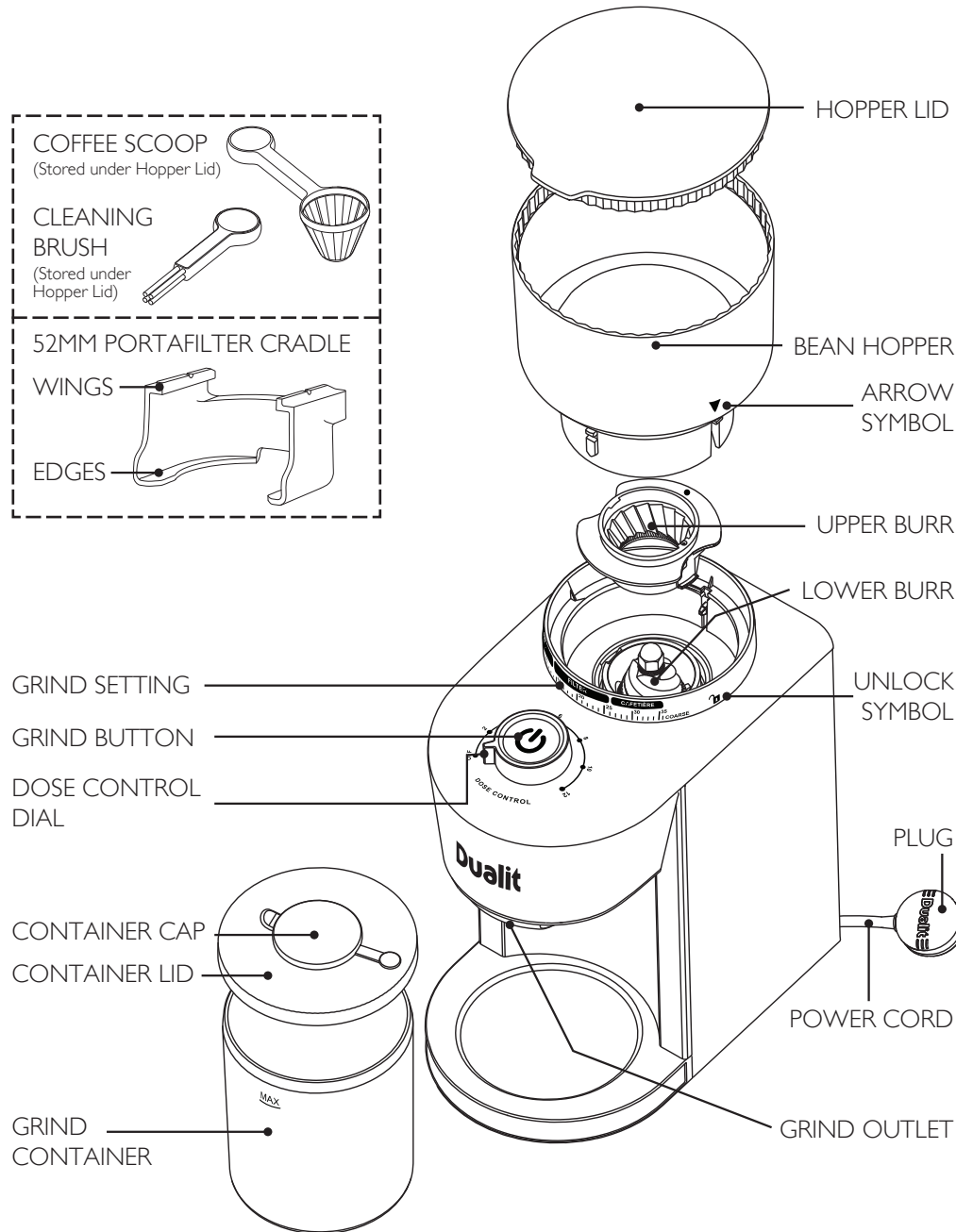
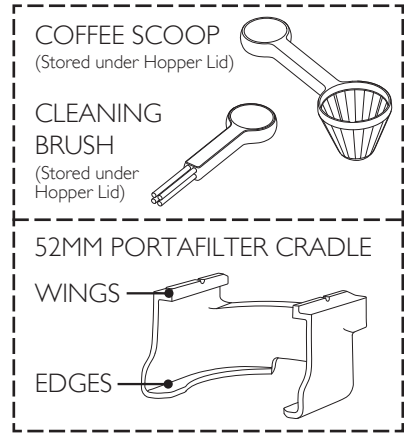

SETTING UP

Remove all packaging materials.
Follow this procedure before first use or after a period of no use.

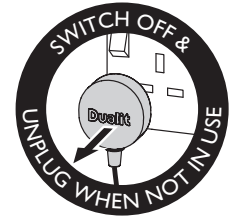

Register your appliance on www.dualit.com. This will only take 60 seconds. You will need the product model and serial number that are on the rating label on the base of the product.

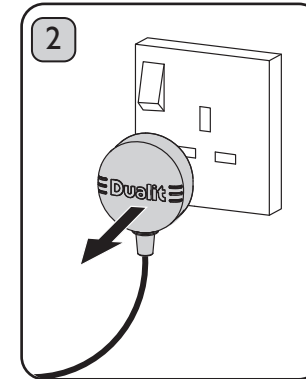

Ensure that the machine is unplugged and the Bean Hopper and Grind Container are empty of packaging material and coffee. Wash the Bean Hopper and Lid, Cradle, Grind Container, Container Lid and Cap in warm, soapy water then rinse and dry thoroughly before reassembling.

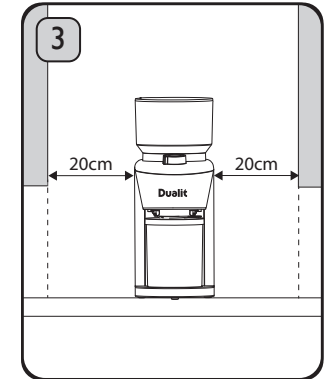

Position in a safe place away from:

- Heat sources. **Risk of fire and electric shock.**
- Water taps. **Risk of electric shock.**
- Do not position: In a cupboard. **Risk of fire.**
- Close to curtains or flammable material. **Risk of fire.**
- On a tray that collects liquid. **Risk of electric shock.**

The surface must be flat in order to keep the machine level and stable. **Risk of injury.**

USING YOUR GRINDER

TO PREVENT OVERHEATING, DO NOT GRIND FOR MORE THAN THREE MINUTES WITHIN ANY 10 MINUTE PERIOD. IF YOU EXCEED THREE MINUTES, THE GRINDER WILL STOP: UNPLUG THE APPLIANCE AND LEAVE TO COOL FOR 30 MINUTES, BEFORE PLUGGING BACK IN AND RESUMING GRINDING. THE GRINDER IS FOR USE WITH ROASTED, WHOLE BEAN COFFEE ONLY. DO NOT ATTEMPT TO GRIND OTHER INGREDIENTS E.G. SPICES, SALT, PEPPER.

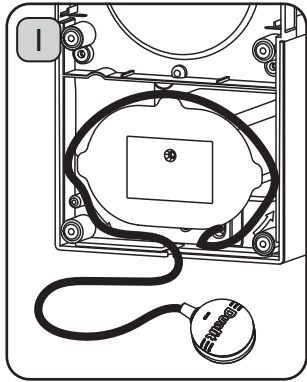

Unreel the required length of cord. It is important to keep the cord short. **Risk of fire or electric shock.** Pack the excess cord length in the cord tidy.

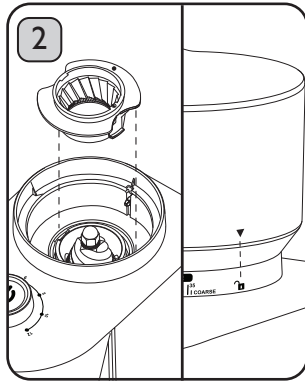

With the machine unplugged, check that the Upper Burr is located correctly. Check that there are no foreign bodies in the Hopper.

Fit the Bean Hopper onto the Main Body by aligning the arrow on the Hopper to the unlock symbol on the Main Body, then rotate clockwise until the arrow aligns with the "FINE" grind setting.

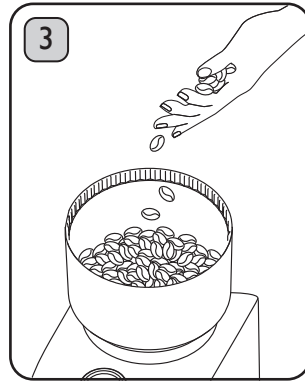

Add fresh coffee beans to the Bean Hopper and secure the Hopper Lid. Remember to only grind what you need. Rotate the Bean Hopper anti-clockwise until the arrow is aligned with the desired grind setting. Refer to Quick Start Grind Settings on page 13. Do not grind past setting 35 as the Bean Hopper may become loose. **Risk of injury.** Note: Check your coffee beans for foreign objects e.g. glass, nails or stones. **Risk of damage and injury to persons.**

GRINDING FOR FILTER AND CAFETIÈRE COFFEE

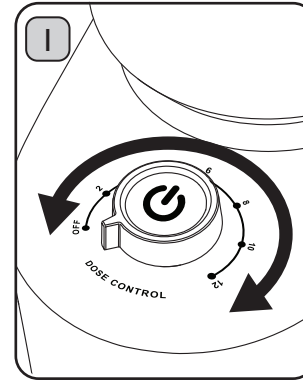
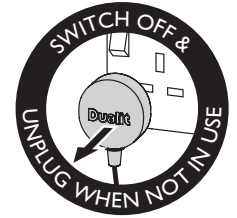

The Dose Control Dial is a rough guide for how many cups of coffee are required. Turn the dial so that the indicator aligns with the number of cups you wish to make. The amount of coffee dosed will change depending on the grind size setting. See page 10 for the Grind Chart.

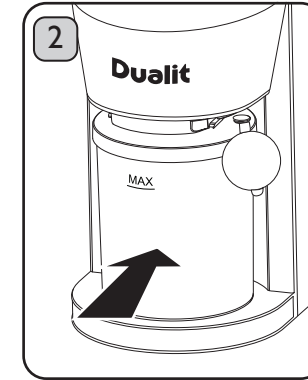

Lift the Container Cap away from the Container Lid. Slide the Grind Container into position, ensuring the Container Cap is positioned away from the Main Body.

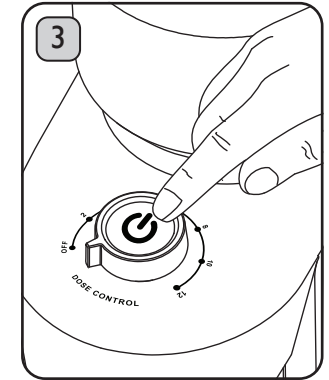

Plug in the Power Cord at the mains and press the Grind Button to start grinding. The Grinder will stop automatically when the selected dose has been dispensed. You can press the Grind Button at any time to manually stop grinding. **NOTE: Do not grind past the 'MAX' indicator on the Grind Container to prevent overheating.**

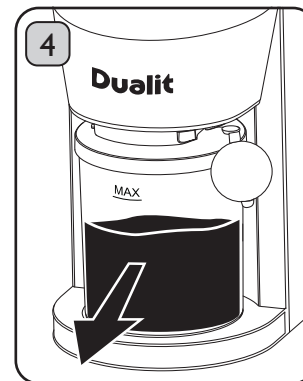

Remove the Grind Container. Tap to loosen grounds before decanting. **NOTE: Unplug after use. Risk of electric shock and fire.**

GRIND CHART

The weight output is based on setting the Dose Control to 2 cups. Note: This chart is a guide only. Bean variety, roast type and moisture content will all affect weight.

Grind size	ESPRESSO			FILTER			CAFETIÈRE		
	1	5	10	15	20	25	30	35	
Weight output (g)	15	16	17	20	23	26	29	30	
	FINE								COARSE

GRINDING FOR ESPRESSO COFFEE

The Portafilter Cradle is designed to fit portafilters that use 52mm baskets. If you have a larger portafilter, grind into the Grind Container, then use the Scoop to measure the coffee into your portafilter. Alternatively, hold your portafilter under the Grind Outlet without the Cradle.

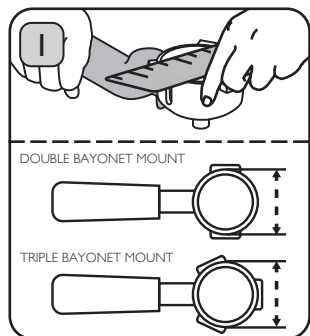

To check whether your portafilter will fit the Portafilter Cradle, measure the outer diameter of your portafilter, as shown. A size of between 59mm and 62mm should be compatible.

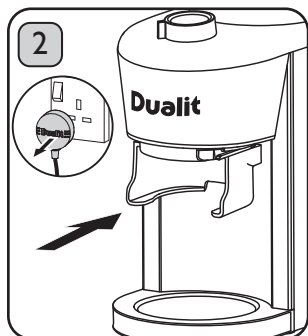

With the appliance unplugged, remove the Grind Container. Slide the Portafilter Cradle, as illustrated, under the Grind Outlet. Plug in the appliance and select a fine grind setting, see page 13 for Quick Start Grind Settings for guide.

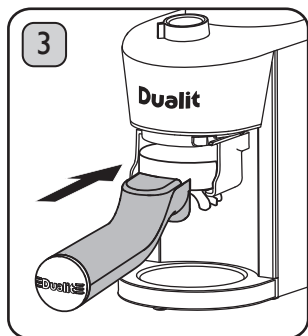

When using the Portafilter Cradle the Dose Control should be set to 2. For accurate dosing and less waste, weigh the amount of beans you need, add to the Bean Hopper, then grind through before tamping to the right level. As a guide, we recommend 7 - 10g for a single espresso and 14-20g for a double.

Alternatively, refer to your coffee machine's instruction manual for guidance.

CLEANING

Follow these steps at the end of each use before storing the appliance, or before changing coffee beans to avoid flavour tainting. **WARNING:** Burrs will have sharp edges. Take care when cleaning. **Risk of injury to persons.**

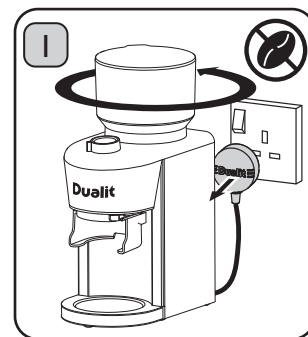

Unplug machine and allow to cool. Rotate the Bean Hopper anti-clockwise until the arrow meets the unlock symbol on the Main Body. Remove the Bean Hopper and empty out any beans into an airtight container to store.

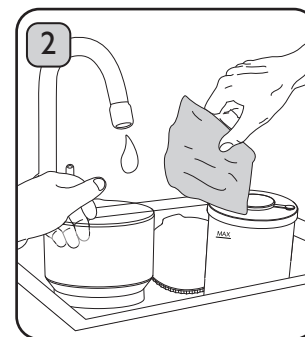

Remove the Grind Container and empty out any remaining coffee. Wash the Grind Container, Container Lid and Bean Hopper in warm, soapy water. Rinse, then dry thoroughly before storing.

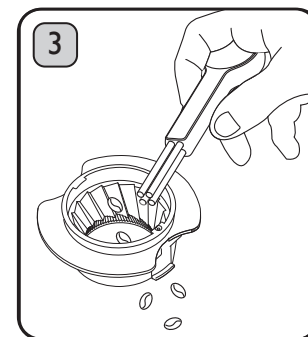

Lift out the Upper Burr and use the Cleaning Brush to remove any coffee. Note: Do not immerse the Upper Burr in water. Remove stubborn coffee build-up with a damp cloth and dry thoroughly.

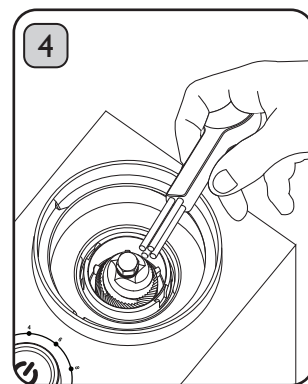

Use the Cleaning Brush to brush away coffee grounds from the Lower Burr.

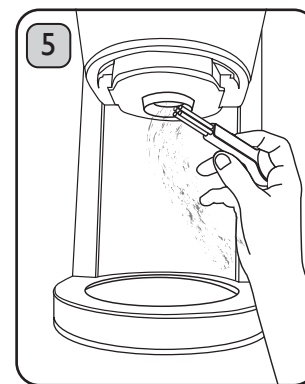

Use the Cleaning Brush to remove any build-up of debris in the Grind Outlet. A torch is useful to check that the Grind Outlet is clean of loose coffee and oil build-up from the beans. If required, use a soft, dry cloth to wipe away stubborn debris. Caution: Do not use sharp implements. **Risk of damage.**

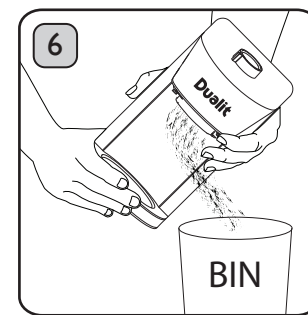

With the appliance unplugged and the Bean Hopper, Upper Burr, Grind Container/Portafilter Cradle removed, tip the Main Body over a bin. This will remove any remaining beans and grounds from the Lower Burr. Wipe down the Main Body of the machine with a damp, non-abrasive cloth. NOTE: Do not clean any Grinder parts or accessories in the dishwasher.

HINTS AND TIPS

- Grinding coffee is messy and coffee grounds will spill! Using your Grinder on a clean, dry, flat surface will make it much easier to quickly wipe away spilt grounds straight into your food waste bin.
- To create as little waste as possible, weigh the exact amount of beans you need to make your coffee before adding to the Bean Hopper.
- For the perfect espresso, you need a steady flow where 35ml takes between 20-30 seconds to extract. The crema should be thick and not dissipate too quickly.
- If the flow is too quick, producing weak crema, try using a finer grind setting or grinding more coffee. If the flow is too slow, try a coarser grind setting or less coffee.
- Do not leave coffee in the Bean Hopper; empty into and store in an airtight or vacuum sealed container.

QUICK START GRIND SETTINGS

FINE			
BREWING STYLE/ MACHINE	GRIND SETTING (FROM DIAL)	IDEAL COFFEE RESULT	GRIND ADJUSTMENT ADVICE
Espresso Coffee Machines Single and double wall filter	1-15 Texture of flour or fine sugar.	Steady flow, 35ml shot extracted in 20-30 seconds with thick, lasting crema.	Flow is too quick producing weak crema – use finer grind or more coffee. Flow is too slow – use coarser grind or less coffee.
Moka Pots		Strong coffee flavour, like that of an espresso.	Weak/acidic coffee – use finer grind. Bitter coffee – use coarser grind.
Aeropress		Varies with your favourite Aeropress recipe, 1-4 minutes brewing time for a strong coffee flavour.	Weak/acidic coffee – use finer grind or brew for longer. Unable to push down plunger – use coarser grind.
Pour Over Coffee		Water continues to drip through coffee for 20-60 seconds after you have finished pouring water.	Flow is too quick producing weak/acidic coffee – use finer grind. Flow is too slow producing bitter coffee – use coarser grind.
Cold Brew Drip style		One drip every 1-2 seconds.	
MEDIUM			
BREWING STYLE/ MACHINE	GRIND SETTING (FROM DIAL)	IDEAL COFFEE RESULT	GRIND ADJUSTMENT ADVICE
Vacuum Pots	15-25 Texture of sand.	Coffee saturated for 90 seconds and drawn through filter for another 90 seconds.	Weak/acidic coffee – use finer grind. Bitter coffee – use coarser grind.
Drip Coffee Makers/ Filters		Water takes about 5 minutes to fully drip through coffee.	Flow is too fast producing weak/acidic coffee – use finer grind. Flow is too slow producing bitter coffee – use coarser grind.

COARSE			
BREWING STYLE/ MACHINE	GRIND SETTING (FROM DIAL)	IDEAL COFFEE RESULT	GRIND ADJUSTMENT ADVICE
Coffee Cupping	25-35	SCA (Specialty Coffee Association) cupping guidelines advise 70% to 75% of the particles passing through a U.S. Standard size 20 mesh sieve.	
Percolator	Texture of sea salt or ground peppercorns, each separate particle is visible.	Froth formed on coffee surface, coffee grounds remain in drink.	Grounds do not sink to bottom of cup or need to be filtered – use finer grind.
Cold Brew Immersion style		Steady flow, 35ml shot extracted in 20-30 seconds with thick, lasting crema.	Flow is too quick producing weak crema – use finer grind or more coffee. Flow is too slow; use coarser grind or less coffee.
Cafetière			

TROUBLESHOOTING



***TO CONTACT CUSTOMER SERVICES, PLEASE EMAIL INFO@DUALIT.COM WITH YOUR MODEL AND SERIAL NUMBERS.**

POSSIBLE CAUSE(S)	SOLUTION(S)
THE GRINDER DOES NOT START AFTER PRESSING THE GRIND BUTTON	
1. The appliance may not be properly connected to the power supply.	1.1 Check that the Plug is in the socket and the switch is turned on 1.2 Check and replace the fuse if necessary. Note: in order to open the Plug, remove the label to reveal the screw.
2. The Bean Hopper may not be positioned correctly.	2.1 Check for any loose beans or grounds caught in the burrs and remove using the Cleaning Brush. If the Upper Burr is not in position, the Bean Hopper will not tighten correctly. 2.2 Position the Bean Hopper by aligning the arrow on the Hopper with the unlock symbol on the Main Body. Turn clockwise to secure.
3. The appliance has overheated.	3.1 If you grind for more than three minutes in any 10 minute period, the Grinder will stop. Switch off, unplug and leave to cool for 30 minutes before resuming grinding. 3.2 A coffee bean or foreign object may have lodged in the burrs, causing the appliance to overheat and activating the current limiting device. Remove the object and leave the appliance to cool for 30 minutes before resuming grinding. If the appliance still will not grind, contact Dualit Customer Services.*
4. A power surge has activated the current limiting device.	4. Contact Dualit Customer Services* for help.
THE MOTOR STARTS BUT NO GROUNDS COME FROM THE GRIND OUTLET	
1. The Bean Hopper is empty.	1. Add fresh coffee beans to the Bean Hopper.
2. The Burrs are blocked.	2. Remove the Bean Hopper and then the Upper Burr. Check for any blockages in the Upper and Lower Burrs and remove. See page 11 for cleaning instructions.
3. A build-up of oil and/or coffee is blocking the Grind Outlet	3. Clean the Grind Outlet with the Cleaning Brush. Use a soft, dry cloth to remove any stubborn particles. See page 11 for cleaning instructions.
THERE IS A LOUD NOISE EMITTING FROM THE APPLIANCE WHEN GRINDING	
1. There is a foreign body blocking the Burrs or Grind Outlet.	1.1 Unplug and remove the Bean Hopper. Check for any loose beans or grounds caught in the burrs and remove using the Cleaning Brush. 1.2 Remove the Grind Container and check the Grind Outlet by using a torch. Use the Cleaning Brush or soft, dry cloth to remove any debris.

GUARANTEE

This appliance is of excellent quality and construction. However, if any defects in materials or workmanship do appear during the relevant guarantee period, we will, at our discretion, either repair or replace the defective parts, free of charge, subject to the terms and conditions of our Guarantee shown below.

This Guarantee covers both parts and labour. Carriage is not included.

Your Guarantee period is as follows:

- 1 year

This Guarantee provides benefits which are additional to, and do not affect, your statutory rights. This Guarantee does not cover the cost of returning the product to the dealer from whom it was purchased or to ourselves. This Guarantee applies only to products sold and located in mainland Great Britain. It does not cover liability in respect of or replacement of plugs, cables or fuses and also does not cover defects due to:

- Failure to use or maintain product in accordance with Dualit's instructions.
- The product being connected to an unsuitable electricity supply.
- Accidental damage to or abuse or misuse of the product.
- Product modification except by Dualit or approved agent.
- Dismantling of or interference with the product.
- Theft or attempted theft of the product.

Before returning any product under this Guarantee, please check that:

- You have followed the product instructions correctly.
- Your mains electricity supply is functional.
- The defect is not due to a blown fuse.

If you wish to claim under this Guarantee you should:

- Send the product, postage or carriage paid, to the dealer from whom it was purchased or to Dualit direct.
- Ensure that the product is clean and packed carefully (preferably in its original carton).
- Enclose details of your name, address and telephone number and when and where the product was purchased, together with proof of purchase (e.g. a till receipt).
- Give exact details of the nature of the defect.

This Guarantee does not cover any other claims whatsoever, including, without limitation, any liability for incidental, indirect or consequential damage, nor does it cover any claims for conversion or modification or for the costs of repair carried out by any third party without the prior consent of Dualit. If replacement parts are fitted to the product this will not extend the period of the Guarantee.

For further advice contact the Dualit customer helpline on +44 (0)1293 652 500 (09:00 to 17:00 Monday to Friday).

Alternatively, email Dualit at info@dualit.com or visit www.dualit.com