

Conveyor Toaster

Installation, Operation and Guarantee
Original Instruction

Dualit®

Since 1945

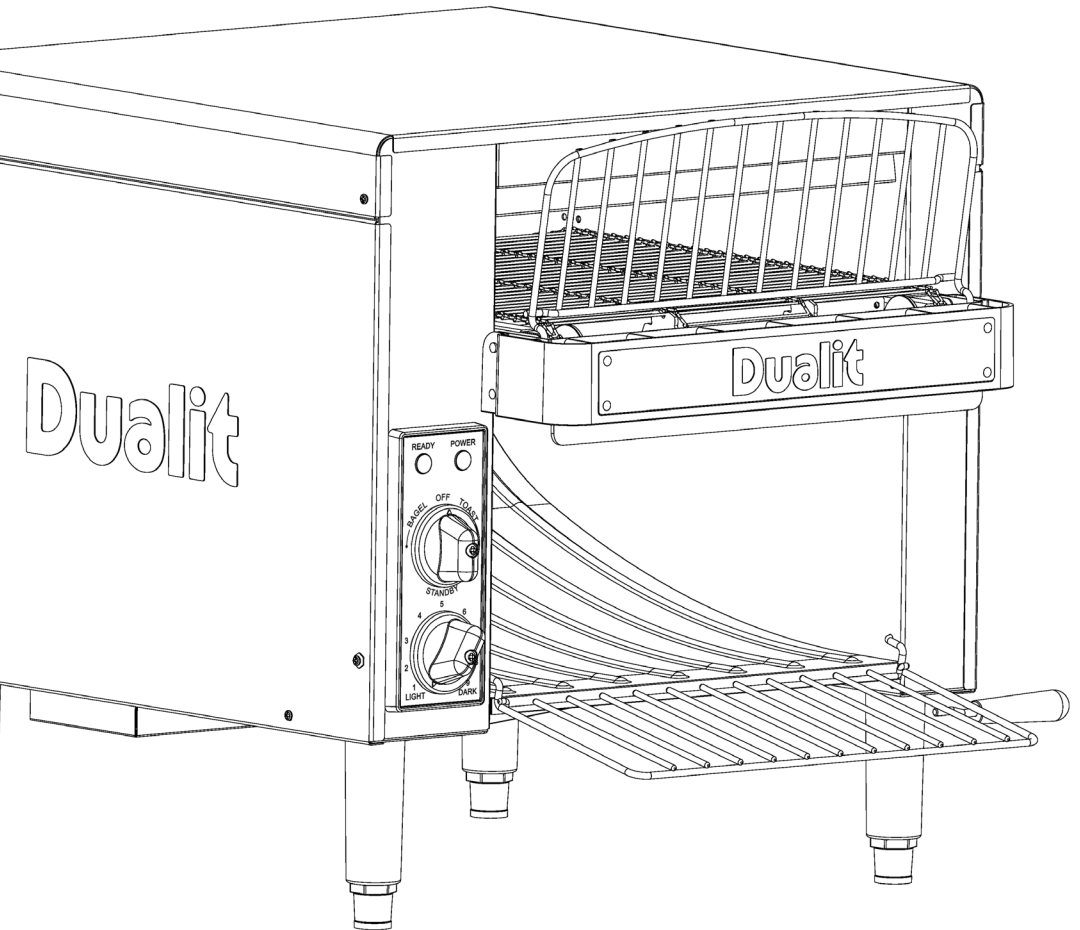

CONTENTS

Safety Precautions	03
Before First Use	05
Know Your Conveyor Toaster	06
Set Up	08
Use	10
Cleaning - Daily	13
Thermal Protection Device	14
Troubleshooting	16
Guarantee	18

REGISTER YOUR PRODUCT

- 1. Fast and efficient customer service** important safety advice, access to manuals and product information should you require assistance with your purchase.
- 2. A library of mouth-watering recipes** and regular articles and blogs.
- 3. Be the first to hear** about exciting new Dualit products.

Dualit recommends safety first: please register your product so that we can contact you in the unlikely event that a safety notification is issued. Remember to keep your receipt as proof of purchase.

DON'T FORGET
TO REGISTER
YOUR PRODUCT

WWW.DUALIT.COM/REGISTER

OR BY POST



Unpack the box with care, keeping all the packaging materials until you are satisfied everything is present and in working order. Once satisfied remove any tags from the appliance body and recycle the packaging appropriately. Do not remove tags from the cord. You may wish to keep the box to store your appliance.

All illustrations are for representation only, your model may have a different appearance from illustrations shown.



IMPORTANT SAFETY PRECAUTIONS

READ ALL INSTRUCTIONS

BEFORE USING THE PRODUCT. KEEP THESE INSTRUCTIONS FOR FUTURE REFERENCE.

IMPORTANT SAFEGUARDS

- **THIS IS AN ATTENDED APPLIANCE. Do not leave unattended during use, unplug after each use (risk of fire if an unattended appliance is left operating).**
- This appliance must not be used by children younger than 8 years old and persons with very extensive and complex disabilities. Children aged 8-14 years and persons with reduced physical, sensory or mental capabilities or lack of experience and knowledge shall not use this appliance, unless they are supervised and have been given instruction concerning the use of the appliance in a safe way and understand the hazards involved. Close supervision is necessary when any appliance is used by or near children. Children shall be supervised to ensure that they do not play with the appliance. Cleaning and user maintenance shall not be made by children unless they are older than 8 and supervised. Keep the appliance and its cord out of reach of children less than 8 years old. **Risk of fire, electric shock, scalding and injury to persons.**
- This appliance is intended for indoor professional use only. Do not use outdoors.
- This appliance is only to be installed in locations where its use and maintenance is restricted to trained personnel.

Electrical Safety

- Before plugging in, check that the voltage on the rating label is the same as the mains supply. **Risk of electric shock and fire.**
- Never plug an appliance into a socket/outlet with other appliances connected to it or a socket/outlet with additional features such as, but not limited to, USB sockets, built-in Wi-Fi boosters, remote Wi-Fi/Bluetooth or similar smart switching functionality. Failure to do this may cause an overload, trip a circuit breaker or blow a fuse. **Risk of electric shock and fire or damage to socket/outlet and plug.** The socket/outlet should be protected by a Residual Current Device (RCD).
- Unplug from outlet when not in use and before cleaning. Allow to cool before putting on or taking off parts. **Risk of fire, electric shock, scalding or injury to persons.**

- Should the light remain illuminated after using the appliance, immediately unplug the appliance and call Dualit's Customer Helpline on +44 (0)1293 652 500. **Risk of electric shock.**
- The toaster is not intended to be operated by means of an external timer or separate remote control system. **Risk of fire.**
- To be protected against electrical hazards, fire and injury to persons, do not immerse the power cord, plug or appliance in water or any other liquid. **Risk of electric shock.**
- **NOTE:** Any plug cut from the power supply cord should be disposed of immediately. Inserting any cut off plug into a socket-outlet is hazardous. **Risk of electric shock and fire.**
- Do not operate any appliance with a damaged lead or plug, or after the appliance malfunctions or has been dropped, damaged or cracked in any manner. **Risk of electric shock and fire.**
- In order to avoid a hazard, if the Power Cord is damaged it must, for safety reasons, be replaced by Dualit or a qualified electrician. Call Dualit's Customer Helpline on +44 (0)1293 652 500. **Risk of electric shock and fire.**
- Never use the plug without the fuse cover fitted. Ensure replacement fuse is the same current value as the original. Replacement fuses are available and should be ASTA approved to BS1362. **Risk of electric shock and fire.**
- Never touch the appliance or Power Cord with wet hands. **Risk of electric shock.**
- **WARNING!** This appliance must be earthed. **Risk of electric shock and fire.**
- The use of extension cables not authorised by the manufacturer may cause damage or accidents. **Risk of electric shock.**
- Do not insert hands, implements, or any metallic or sharp utensils into the toaster. **Risk of damage and electric shock.**

General Safety

- Do not use foods, including tarts and pastries, that may drip fillings or coatings containing sugar when heated in your toaster, as may cause a fire. **Risk of fire.**
- Do not allow the device to freeze. This may compromise electrical safety and will degrade performance of all lubricants. **Risk of electric shock and damage.**
- Bread may burn, therefore do not use the toaster near or below combustible material such as curtains. **Risk of fire.**
- If using the appliance close to a wall, ensure this is clad with non-combustible material and adheres to fire prevention regulations. **Risk of fire.**



IMPORTANT SAFETY PRECAUTIONS

- When in use a fire may occur if the appliance is covered or touching flammable material, including curtains, draperies, walls and the like. **Risk of fire.**
- In case of fire, disconnect from the power source immediately.
- Do not place on or near a hot gas or electric burner or in a heated oven. **Risk of fire.**
- Do not attempt to dislodge bread when the toaster is plugged in. **Risk of electric shock**
- Crumb tray must be in place during toasting. **Risk of fire.**
- Crumb tray should be regularly cleaned. A build up of crumbs can burn or cause a fire. **Risk of fire and injury.**
- Do not operate unit without crumb tray as this will cause uneven toasting and possible over heating of the appliance. **Risk of fire.**
- Do not allow cable to touch hot surfaces, or to hang over edge of a table or counter top. **Risk of fire or electric shock.**
- Do not use appliance for any purpose other than the intended use. **Risk of fire, electric shock, burns or injury to persons.**
- Do not store or use in an appliance garage or under cupboards. **Risk of fire.**
- Do not store or use gasoline or other flammable materials near the appliance. **Risk of fire.**
- Do not use if dropped, cracked or damaged. **Risk of burns and electric shock.**
-  Accessible surfaces of the appliance may get hot during use. Therefore use handles or knobs. **Risk of burns.**
- The appliance will remain hot after use. **Risk of burns.**
- The machine must only be operated on a flat surface. **Risk of fire and electric shock.**
- Do not place the appliance on a polished wood, marble or porous surface. **Risk of property damage.**
- Do not use scouring pads or abrasive cleaner on the appliance body. **Risk of damage.**
- The use of accessory attachments not recommended by Dualit **may result in fire, electric shock or injury to persons.**
- Keep body parts away from moving parts of the appliance. Tie hair back and remove loose clothing or jewellery to avoid them getting caught. **Risk of injury.**
- Never put the appliance or part of it in a dishwasher. **Risk of damage and electric shock.**

- The appliance must not be cleaned by a water jet or steam cleaner. **Risk of burns and scalding.**
- Keep area around the Air Intake clear. **Risk of fire.**
- Do not place anything on top or near the sides/ underneath of the appliance. **Risk of fire.**
- Do not modify the appliance. **Risk of fire and electric shock.**
- Remove all packaging before use. **Risk of fire.**
- Do not put a pan on top of the toaster or warming rack. **Risk of fire, electric shock, scalding or injury to persons.**
- Never touch the Conveyor Belt. **Risk of injury.**

SAVE THESE INSTRUCTIONS

In the interest of improving products, Dualit Ltd. reserves the right to change the product specification without prior notice. All illustrations are for representation only, your model may vary from illustrations shown.



INSTRUCTIONS ON ENVIRONMENT PROTECTION

Do not dispose of this product in the usual household garbage at the end of its life cycle. Please hand it over to a collection point for the recycling of electrical and electronic appliances. The symbol on the product, the instruction of use or the packaging will inform you about the methods of disposal. The materials are recyclable as mentioned on its marking. By recycling, material recycling or other forms of re-utilization of old appliances you are making an important contribution to protect our environment. Please enquire at the community administration for the authorised disposal location.



IMPORTANT: BEFORE FIRST USE

- Read this instruction manual before you start using the appliance. It gives you important safety information and will ensure you get the most out of your Dualit product.
- Make sure all people associated with the appliance's use understand the operation and safety before they use the unit.
- Keep this manual and your proof of purchase in a safe place.
- Don't forget to register your product at www.dualit.com/register.
- Before you use your toaster for the first time, wash all parts according to the cleaning instructions.
- Position the toaster according to the Safety Precautions and Setting Up procedure. **Risk of fire, electric shock, scalding or injury to persons.**
- When you turn the appliance on for the first time, a "new" smell may be given off; this will dissipate after a few uses.
- Unpack the box with care, keeping all the packaging materials until you are satisfied everything is present and in working order. Once satisfied recycle the packaging appropriately.

KNOW YOUR CONVEYOR TOASTER

MODEL: DCT2I



FUSED PLUG

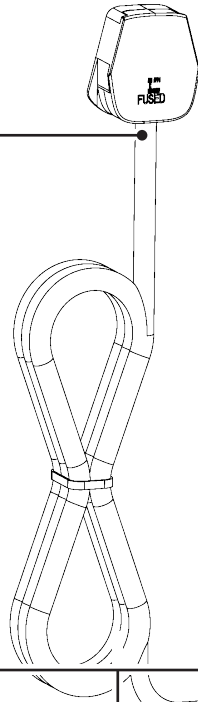

CONTROLS

READY INDICATOR

ILLUMINATES GREEN WHEN THE TOASTER IS QUICK START READY. SEE PAGE 10 FOR DETAILS.

POWER INDICATOR

ILLUMINATES RED WHEN THE TOASTER IS PLUGGED IN AND SWITCHED ON.

FUNCTION CONTROL DIAL

USE TO CHANGE THE TOASTING FUNCTION: TOAST, BAGEL, STANDBY OR OFF.

TOAST SETTINGS DIAL

USE TO ADJUST BROWNESS OF YOUR BREAD:
SETTING 1 - LIGHTEST
SETTING 9 - DARKEST

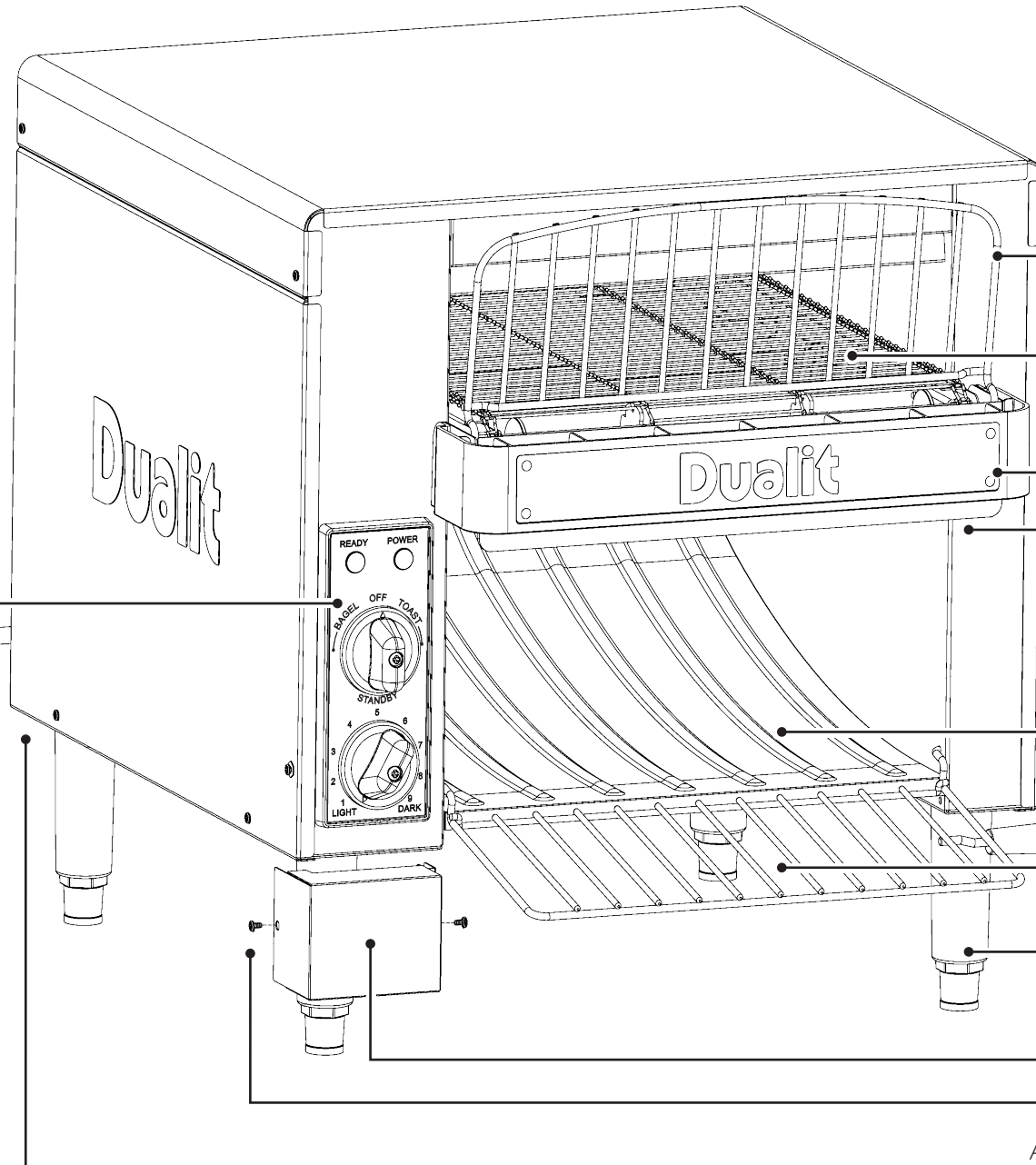
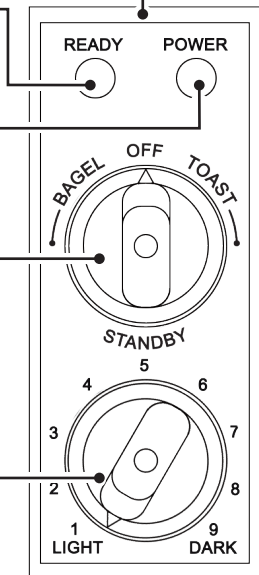

BREAD RAMP

CONVEYOR BELT

KNUCKLE GUARD

REMOVABLE CRUMB TRAY

BREAD SLIDE

TOAST RAMP

LEGS

ANTI-TAMPER GUARD

M4 X 10.0MM SCREWS
FIT WITH PHILLIPS HEAD SCREWDRIVER

AIR INTAKE UNDER MACHINE

SETTING UP YOUR CONVEYOR TOASTER

Note: Before setting up your Conveyor Toaster ensure that you remove the legs and Anti-Tamper Guard from the polyfoam insert in the bottom of the box.



1 REGISTER MY APPLIANCE

Register your appliance at www.dualit.com. This will only take 60 seconds. You will need the product model and serial numbers that are on the rating label on the base of the product.

2 UNPACK

REMOVE PACKAGING BEFORE INSTALLATION

Caution: ensure all packaging material is removed from the Conveyor Toaster. Remember to keep it until you are satisfied that everything is present and functional.

3 ATTACH LEGS

x4

Carefully place your Conveyor Toaster on its side. Thread all 4 legs into the holes shown and tighten using a 21mm spanner. Pick up and place the Conveyor Toaster on its feet. **Caution: do not operate without all legs secured.**

7 DON'T STORE UNDER CUPBOARDS

Ensure your Conveyor Toaster is not stored in an appliance garage or underneath cupboards. Overheating may occur if the appliance is not correctly positioned. **Risk of fire.**

8 DON'T STORE NEAR CURTAINS

Do not store or use your Conveyor Toaster next to curtains or flammable material. **A fire may occur if incorrectly positioned.**

9 POSITION

Place the Conveyor Toaster on an open level surface. Ensure that it is positioned 100cm away from any overhanging cupboards or ceilings.

4 POSITION CRUMB TRAY

Position the Crumb Tray into the mounting rails beneath the Conveyor Belt. **Caution: Failure to do so could cause the appliance to overheat.**

5 POSITION RAMPS

Position the Bread and Toast Ramps as shown above. Note: Once the Bread Ramp has been positioned, it cannot be moved. Dualit recommend having a basket underneath the Toast Ramp to catch toasted items.

6 WIPE MACHINE

Take time to wipe down your Conveyor Toaster with a damp cloth to ensure it is ready for toasting.

10 POSITION

Ensure the Conveyor Toaster is positioned at least 50cm clear from walls. For best results use away from drafts. Warning: do not use near water sources.

11 NEVER COVER THE VENTS

Never cover the vents on the sides of the Conveyor Toaster. **This will prevent necessary air flow and could cause a fire.**

12 CAUTION: HOT SURFACES!

Caution: The surfaces of the Conveyor Toaster will get extremely hot during operation. Ensure to touch only the dials when in use, as risk of scalding. Do not place items on top of the Conveyor Toaster, in particular plastic such as bread bags that could melt.

USING YOUR CONVEYOR TOASTER

CORRECT TOAST SETTING: IMPORTANT INFORMATION

Your Conveyor Toaster is designed to toast bread products in buffet and kitchen environments. To achieve optimum performance, make sure that any user understands how to operate and control the toaster for intended use.

Note: For new toasters, or those that haven't been used in a while, follow the Setting Up guide on page 8

WARM UP PROCEDURES: FULLY WARM AND QUICK START

FULLY WARM START UP PROCEDURE

Dualit always recommends this procedure when time is available. Switch on and allow your Conveyor Toaster to run empty. The Conveyor Toaster will be fully warm after 30 minutes. This procedure produces the most consistent toasting results and no adjustment of the toast settings are required by the operator once toasting has started. See the diagram below and the table on page 11 which help explain the differences between Quick Start and Fully Warm start procedures.

QUICK START PROCEDURE

If time is short, the Conveyor Toaster can be ready to start toasting in as little as 5 minutes. As soon as the green Ready Indicator illuminates, you can start toasting. Begin by using the Usage Type and toast setting for your bread as per the table on page 11. The Toast Chamber will continue to heat up for 30 minutes until it reaches Fully Warm, after which it is important to reduce the toast settings in order to maintain the consistent browning of your toast. Dualit recommend that after 10 minutes of Quick Start toasting, the operator should reduce the toast settings to half-way between the initial Quick Start toast setting and the Fully Warm toast setting. See the table on page 11 for more information.

TOASTER WARM UP CHART

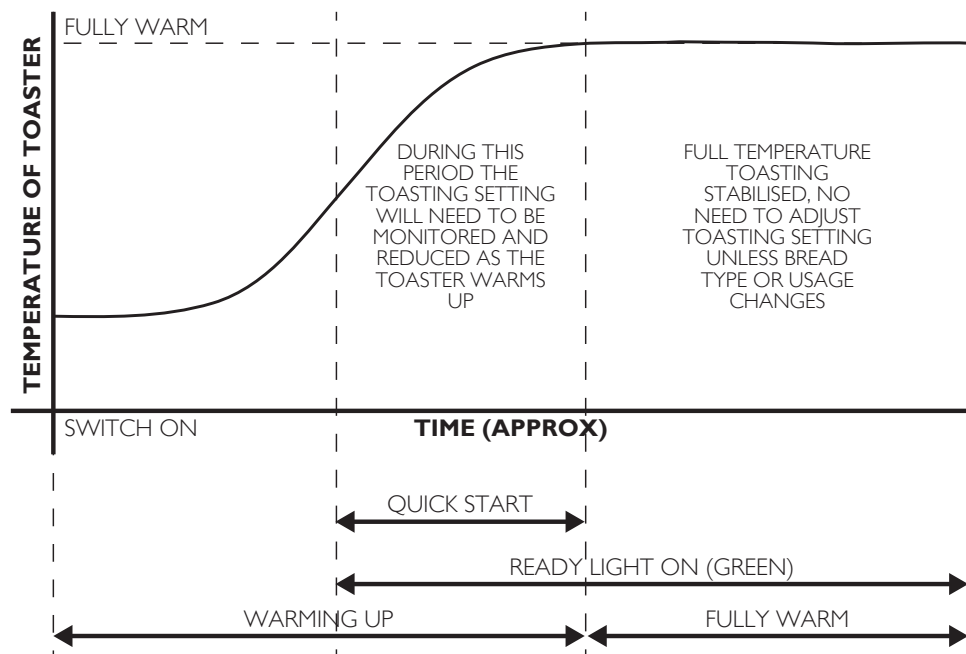

TOASTING

Plug in and switch on your Conveyor Toaster at the wall. Choose your function by turning the Function Control Dial to the desired setting.

Toast: Top and bottom elements are on. Both sides of the bread will be toasted.

Bagel: Only bottom element is on. Place bagels cut side down on the conveyor.

Standby: Do not use for toasting. See page 12 for details.

Using the table below as a guide, adjust the Toast Settings Dial based on how you like your bread; clockwise for darker and anti-clockwise for lighter.

Type of Bread	Quick Start - Toast Setting			Full Temperature - Toast Setting		
	Continuous	Intermittent	Buffet	Continuous	Intermittent	Buffet
White	6	5.5	5	5	4.5	4
Granary	9	8.5	8	6	5.5	5
Fruit Bread	4	3.5	3	2.5	Not recommended*	
Rye	Not recommended**			9	8.5	8
Bagel	6.5	6	5.5	6	5.5	5

*Toaster will be too hot so will burn the bread. **Risk of fire.** **Bread will not toast properly and will be soggy.

USAGE TYPES

Continuous Toasting (toast every 1-5 secs)

Back to back or larger batches.

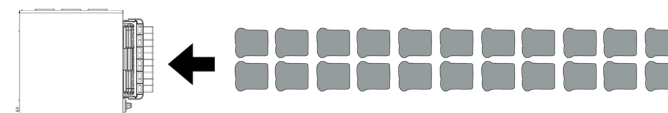

Intermittent Toasting (toast every 5-30 secs)



Buffet Toasting (toast every 30+ secs)

#Irregular intervals over 30 seconds, used on demand.

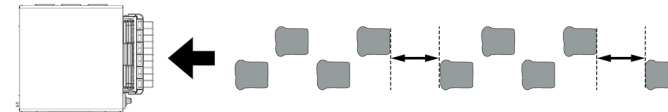

Reminder

- If using the toaster front of house, we recommend selecting a suitable browning colour for the days delivery of bread before service starts, and that Quick Start is not used. It is also recommended that the Anti-Tamper Guard is fitted to prevent customers changing the settings. See page 13 for details.
- To achieve the maximum performance from your Conveyor Toaster, load continuously as per the diagram above. For best results use day old bread.
- When swapping between functions; toasting continuously or intermittently, or changing bread type, you should adjust your toast settings. See the table above for recommendations.
- When it's time to turn off your Conveyor Toaster, change the Function Control to 'OFF', wait for the Cooling Fan (audible) to stop, switch off and unplug the appliance from the wall. Note: The Cooling Fan can take up to 10 minutes to switch off. **Warning: Fire risk if appliance is left unattended at any time.**

STANDBY MODE

During periods of inactivity, you can use Standby Mode to reduce the power consumption of your appliance by up to 70%. When you are ready to go again, switch the control dial to either 'TOAST' or 'BAGEL' and, in normal conditions, your machine will be ready to toast in just 2 minutes; that's a 50% time saving over Quick Start.

After 15 minutes on standby, your Conveyor Toaster will have used the same amount of energy as it would to get from room temperature to Quick Start temperature. As such, Dualit recommends switching the device off if you don't intend to use it for longer than 15 minutes.

TOASTER STANDBY CHART

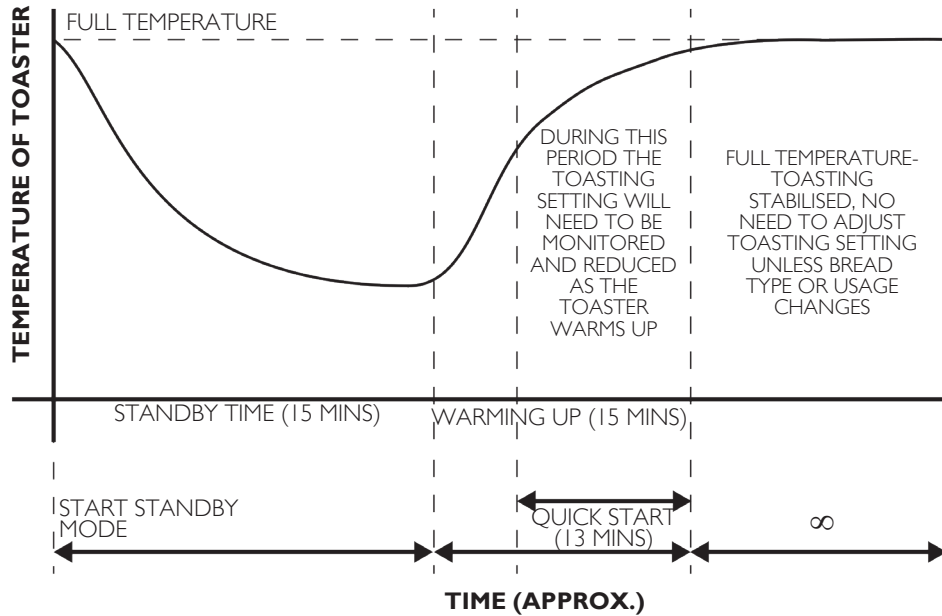

Your toaster is fitted with a temperature limiting thermostat. During periods of inactivity, longer than 5 minutes, the elements will turn off (indicated by the red power indicator going off). Only introduce bread to the conveyor when the red light is on and the elements are glowing cherry red.

TECHNICAL PARAMETERS

	14kg	560 slices per hour
See the data plate on the base of the machine		
	W: 430 mm x H: 413 mm x D: 512 mm	

ANTI-TAMPER

Your Conveyor Toaster features a removable Anti-Tamper Guard. Note: Before setting up your Conveyor Toaster, ensure that you remove the legs and Anti-Tamper Guard from the polyfoam insert in the bottom of the box. For buffet environments, Dualit recommends fitting the Anti-Tamper Guard to avoid customers adjusting the Toast Settings Dial. The Guard should be fitted using M4 x 10.0mm screws and a Phillips head screwdriver. After selecting the correct toast settings, the Anti-Tamper Guard can be fitted as follows.

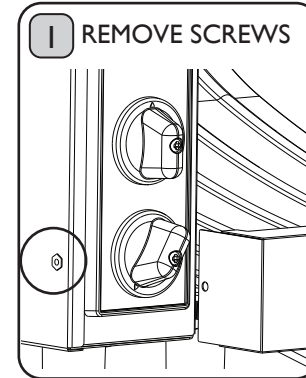

Remove the two screws seen on the left and right-hand sides of the controls. Align the Anti-Tamper Guard with the screw holes.

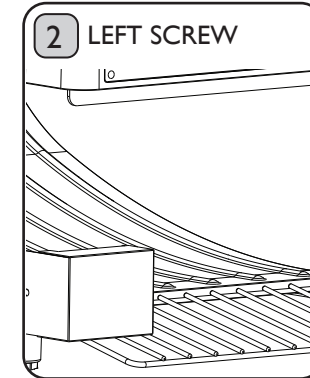

Insert and tighten the left-hand screw.

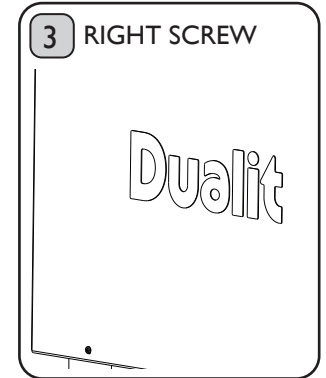

Insert and tighten the right-hand screw. To remove, repeat in reverse order.

CLEANING - DAILY

Before cleaning your Conveyor Toaster, tie hair back and ensure that you are wearing no loose clothing or jewellery. **NEVER ALLOW A BUILD UP OF CRUMBS IN THE CRUMB TRAY AS THIS MAY CAUSE A FIRE. CLEAN DAILY.**

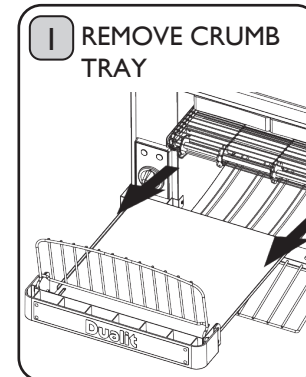

Remove the Crumb Tray. From a cold start, set the Conveyor Toaster to standby. Select toast setting 9. As the conveyor rotates, clean the exposed section of the belt. Wipe with a damp, non-abrasive cloth if lightly soiled or a dry, lightly abrasive pad if heavily soiled. Then wipe with a damp cloth.

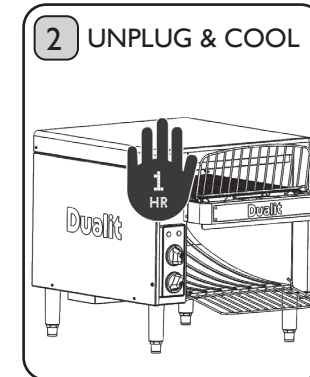

Unplug from mains, leave to cool for minimum of 1 hour; then wipe all external surfaces with a damp, non-abrasive cloth.

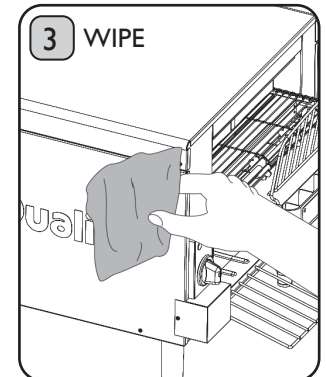

Remove Crumb Tray, tip out all of the crumbs, then clean with a damp cloth and replace. Ensure the area around the Conveyor Toaster is clean and crumb free. Clean the fan air intake with a damp, non-abrasive cloth.

THERMAL PROTECTION DEVICE

Your Dualit Conveyor Toaster is fitted with a Thermal Protection Device. This is intended to protect the product and user in the event of a thermal overheat. The Thermal Protection Device will activate if:

1. There is insufficient ventilation surrounding the product. **Warning:** Always follow Set Up Procedure (see page 8).
2. There is a fault with the product.

If you find that your toaster's red "POWER" light is not illuminating, the belt is not turning and the elements are not heating, the Thermal Protection Device may have activated.

First check the Plug Fuse and replace if necessary. If the toaster's red "POWER" light is still not illuminating, you need to reset the Thermal Protection Device.

RESETTING THE THERMAL PROTECTION DEVICE

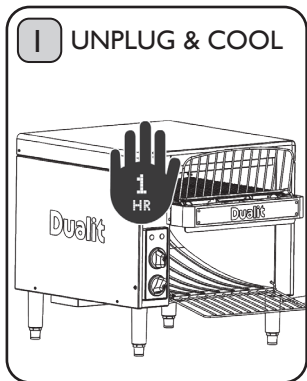

Turn off and unplug the toaster. Allow to cool for 1hr. **Risk of electrocution and burns.**

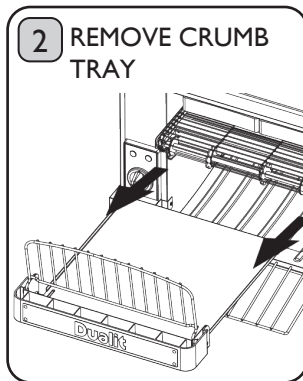

Remove the Crumb Tray and lay the toaster on its right hand side, onto a cloth to protect the surfaces, to gain access to the reset button. **Warning:** Take care not to pull or knock the legs when turning the product over. Damage may occur.

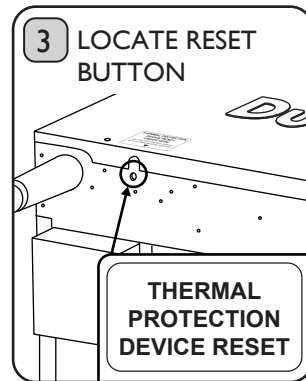

Locate the Reset Button that is situated on the underside of the toaster on the left hand side. You can identify the location by the marking that says "**Thermal Protection Device Reset Under Here**".

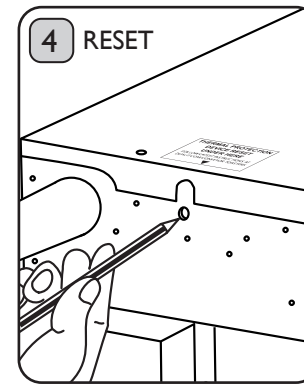

You can use the end of a pen to press the reset button, situated within the hole.

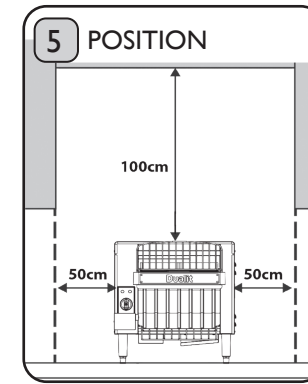

Once reset, ensure toaster is set up and sat back on its legs. Ensure you have positioned it correctly within its environment (see page 8) and plug in. **A fire may occur if incorrectly positioned.**

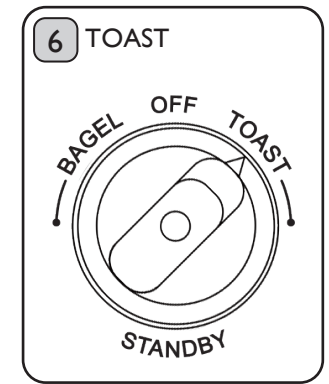

Turn the Control Dial to 'TOAST'.

TROUBLESHOOTING THE THERMAL PROTECTION DEVICE

PROBLEM	SOLUTION(S)
1. The red light still does not illuminate even when the belt is turning.	1. The toaster will need to be returned to Dualit. Please contact customer services on 01293 652500.*
2. The red light has illuminated.	2.1 Allow the Toaster to heat up for 15 minutes. 2.2 If the green "READY" light does not illuminate (after the toaster has been allowed to heat for 15 minutes), then there is a fault with the internal control system of the toaster; you will need to return it to Dualit. Please contact customer services on 01293 652500.*
3. The Thermal Protection Device has to be reset again.	3. There is a fault with the Toaster Thermostat; you will need to return it to Dualit. Please contact customer services on 01293 652500.*

* **IMPORTANT:** If you need to return your product for servicing, the product must be packaged appropriately. Where possible, please use the original packaging. The legs of the Conveyor Toaster **MUST** be removed before packing. Failure to do so will damage your Conveyor Toaster, which your warranty will not cover.



Scan the QR code for packing instructions. If you need a new box or have further questions, contact Dualit Customer Services.

TROUBLESHOOTING



***TO CONTACT CUSTOMER SERVICES, PLEASE EMAIL
INFO@DUALIT.COM WITH YOUR MODEL AND SERIAL NUMBERS.**

POSSIBLE CAUSE(S)	SOLUTION(S)
MY TOASTER ISN'T WORKING	
1. The toaster may not be plugged in.	1. Make sure the toaster is switched on and plugged in correctly to the UK mains.
2. The Plug Fuse may need replacing.	2. The Plug Fuse may need replacing if the Power Indicator does not turn on and the device does not appear to work. Please check and replace the Plug Fuse.
3. The thermal Fuse may need resetting.	3. Please contact Dualit customer services* for help.
THE ELEMENTS CYCLE ON AND OFF	
1. The toaster has a Thermostat which constantly monitors the toaster's running temperature for perfect toast.	1. The elements will cycle on and off at certain temperature to save energy and avoid over cooked toast; no action is needed.
I GET UNEVEN TOASTING	
1. The toaster may not be Fully Warm.	1. Allow the toaster to reach full temperature, this should take 30 minutes depending on conditions. See page 11.
2. Your bread may not be positioned on the Conveyor correctly.	2. Check the edges of the bread are over the elements and not off the edge of the conveyor.
3. The toasting setting you are using may not be appropriate for the bread type.	3. Check the type of bread you are using is appropriate for the toast setting your machine is on; please see page 11.
4. 'BAGEL' setting or 'STANDBY' may be in use.	4. If toasting bread rather than bagels, ensure the toaster is set to the 'TOAST' setting on the front panel. Please see page 11 for more information.
5. An element may have blown.	5. Check all elements glow when the toaster is Fully Warm. If not contact Customer Services* for help.
6. The fan may have stopped.	6. Check if the fan is audible when the Conveyor Toaster is on and the green 'READY' light is illuminated. Ensure the fan is clean as per instructions on page 13. If the fan still appears to have stopped, contact Customer Service* for help.

POSSIBLE CAUSE(S)	SOLUTION(S)
MY TOAST COMES OUT TOO LIGHT	
1. The toast setting may be too low for the type of bread you are using or the conditions that you are using the toaster in.	1. Please see page 11 for information on toasting settings for different bread types and factors that affect toasting.
2. Your Quick Start toast setting may be too low.	2. If using Quick Start, you will need to turn the toast setting up much higher than usual, then dial it back as the toaster heats up. Please see the table on page 11 for more information.
3. Your toaster is fitted with a temperature limiting Thermostat. During periods of inactivity, longer than 5 minutes, the elements will turn off (indicated by the red power indicator going off).	3. Only introduce bread to the conveyor when the red light is on and the elements are glowing cherry red. See page 12 for details.
MY TOAST COMES OUT TOO DARK	
1. The toast setting may be too high for the type of bread you are using or the conditions that you are using the toaster in.	1. Please see page 11 for information on toasting settings for different bread types and factors that affect toasting.
2. Quick Start setting may be too high or is not decreasing enough as the Conveyor Toaster continues to warm up.	2. See pages 10-11 for details. Monitor toast colour and adjust toasting setting as toaster warms up when using Quick Start.
3. Crumb Tray Bread Ramp does not fold flat.	3. This is a safety feature. The Bread Ramp is designed not to fold flat.

GUARANTEE

This appliance is of excellent quality and construction. However, if any defects in materials or workmanship do appear during the first year from purchase, we will, at our discretion, either repair or replace the defective parts, free of charge, subject to the terms and conditions of our Guarantee shown below.

This Guarantee covers both parts and labour. Carriage is not included.

Your Guarantee period is as follows:

If your conveyor toaster fails within one year from date of purchase we will repair or replace it free of charge, except for the elements, provided:

- You have not misused, neglected or damaged it.
- It has not been modified.
- You supply your receipt to show when you bought your toaster.

Elements are guaranteed for 3 months from date of purchase for parts and labour, thereafter parts only. If located in a congestion charge zone, the customer is required to pay the charge. If over one year, contact Dualit for recommended repair agents.

This Guarantee provides benefits which are additional to, and do not affect, your statutory rights. This Guarantee does not cover the cost of returning the product to the dealer from whom it was purchased or to ourselves. This Guarantee applies only to products sold and located in mainland Great Britain. It does not cover liability in respect of or replacement of plugs, cables or fuses and also does not cover defects due to:

- Failure to use or maintain product in accordance with Dualit's instructions.
- The product being connected to an unsuitable electricity supply.
- Accidental damage to or abuse or misuse of the product including failure to use the product for its normal intended purposes.
- The product modified, except by Dualit or approved agent.
- Dismantling of or interference with the product.
- Theft or attempted theft of the product.
- Operational misuse, wear and tear from

normal usage, incorrect adjustment and neglect.

- Incorrect installation, maintenance, modification or unauthorised service work.

Before returning any product under this Guarantee, please check that:

- You have followed the product instructions correctly.
- The defect is not due to a blown fuse. Please check and change the plug fuse.
- Your mains electricity supply is functional.

If you wish to claim under this Guarantee you should:

- Send the product, postage or carriage paid, to the dealer from whom it was purchased or to Dualit direct.
- Ensure that the product is clean and packed carefully (preferably in its original carton).
- Enclose details of your name, address and telephone number and when and where the product was purchased, together with proof of purchase (e.g. a till receipt).
- Please give exact details of the nature of the defect.

This Guarantee does not cover any other claims whatsoever, including, without limitation, any liability for incidental, indirect or consequential damage, nor does it cover any claims for conversion or modification or for the costs of repair carried out by any third party without the prior consent of Dualit. If replacement parts are fitted to the product this will not extend the period of the Guarantee.

For further advice contact the Dualit customer helpline on +44 (0)1293 652 500 (09:00 to 17:00 Monday to Friday).

Alternatively, email Dualit at info@dualit.com or visit www.dualit.com

REGISTER YOUR PRODUCT

1. **Fast and efficient customer service** important safety advice, access to manuals and product information should you require assistance with your purchase.
2. **A library of mouth-watering recipes** and regular articles and blogs.
3. **Be the first to hear** about exciting new Dualit products.

Dualit recommends safety first: please register your product so that we can contact you in the unlikely event that a safety notification is issued. Remember to keep your receipt as proof of purchase.

DON'T FORGET
TO REGISTER
YOUR PRODUCT

WWW.DUALIT.COM/REGISTER

OR BY POST



Dualit®



Dualit Limited County Oak Way Crawley West Sussex RH11 7ST



+44(0)1293 652 500

info@dualit.com