



IMPORTANT SAFETY PRECAUTIONS



READ ALL INSTRUCTIONS

BEFORE USING THE PRODUCT.
KEEP THESE INSTRUCTIONS FOR FUTURE REFERENCE.

IMPORTANT SAFEGUARDS

- **THIS IS AN ATTENDED APPLIANCE. Do not leave unattended during use, unplug after each use (risk of fire if an unattended appliance is left operating).**
- This appliance must not be used by children younger than 8 years old and persons with very extensive and complex disabilities. Children aged 8-14 years and persons with reduced physical, sensory or mental capabilities or lack of experience and knowledge shall not use this appliance, unless they are supervised and have been given instruction concerning the use of the appliance in a safe way and understand the hazards involved. Close supervision is necessary when any appliance is used by or near children. Children shall be supervised to ensure that they do not play with the appliance. Cleaning and user maintenance shall not be made by children unless they are older than 8 and supervised. Keep the appliance and its cord out of reach of children less than 8 years old. **Risk of fire, electric shock, scalding and injury to persons.**
- This appliance is intended for indoor professional use only. Do not use outdoors. **Risk of fire, electric shock, scalding and injury to persons.**
- This appliance is only to be installed in locations where its use and maintenance is restricted to trained personnel. **Risk of fire, electric shock, scalding and injury to persons.**

Electrical Safety

- Before plugging in, check that the voltage on the rating label is the same as the mains supply. **Risk of electric shock and fire.**
- Never plug an appliance into a socket/outlet with other appliances connected to it or a socket/outlet with additional features such as, but not limited to, USB sockets, built-in Wi-Fi boosters, remote Wi-Fi/Bluetooth or similar smart switching functionality. Failure to do this may cause an overload, trip a circuit breaker or blow a fuse. **Risk of electric shock and fire or damage to socket/outlet and plug.** The socket/outlet should be protected by a Residual Current Device (RCD).
- Unplug from outlet when not in use and before cleaning. Allow to cool before putting on or taking off parts. **Risk of fire, electric shock, scalding or injury to persons.**
- Should the light remain illuminated after using the appliance, immediately unplug the appliance and call Dualit's Customer Helpline on +44 (0)1293 652 500. **Risk of electric shock.**
- The toaster is not intended to be operated by means of an external timer or separate remote control system. **Risk of fire.**
- To be protected against electrical hazards, fire and injury to persons, do not immerse the power cord, plug or appliance in water or any other liquid. **Risk of electric shock.**
- **NOTE:** Any plug cut from the power supply cord should be disposed of immediately. Inserting any cut off plug into a socket-outlet is hazardous. **Risk of electric shock and fire.**
- Do not operate any appliance with a damaged lead or plug, or after the appliance malfunctions or has been dropped, damaged or cracked in any manner. **Risk of electric shock and fire.**
- In order to avoid a hazard, if the Power Cord is damaged it must, for safety reasons, be replaced by Dualit or a qualified electrician. Call Dualit's Customer Helpline on +44 (0)1293 652 500. **Risk of electric shock and fire.**
- Never use the plug without the fuse cover fitted. Ensure replacement fuse is the same current value as the original. Replacement fuses are available and should be ASTA approved to BS1362. **Risk of electric shock and fire.**
- **WARNING!** This appliance must be earthed. **Risk of electric shock and fire.**

General Safety

- If using the appliance close to a wall, ensure this is clad with non-combustible material and adheres to fire prevention regulations. **Risk of fire.**
- When in use a fire may occur if the appliance is covered or touching flammable material, including curtains, draperies, walls and the like. **Risk of fire.**
- In case of fire, disconnect from the power source immediately.
- Do not place on or near a hot gas or electric burner or in a heated oven. **Risk of fire.**
- Do not allow cable to touch hot surfaces, or to hang over edge of a table or counter top. **Risk of fire or electric shock.**
- Do not use appliance for any purpose other than the intended use. **Risk of fire, electric shock, burns or injury to persons.**
- Do not store or use in an appliance garage or under cupboards. **Risk of fire.**
- Do not store or use gasoline or other flammable materials near the appliance. **Risk of fire.**

- Do not use if dropped, cracked or damaged. **Risk of burns and electric shock.**
- Accessible surfaces of the appliance may get hot during use. Therefore use handles or knobs. **Risk of burns.**
- The appliance will remain hot after use. **Risk of burns.**
- The machine must only be operated on a flat surface. **Risk of fire and electric shock.**
- Do not place the appliance on a polished wood, marble or porous surface. **Risk of property damage.**
- Do not use scouring pads or abrasive cleaner on the appliance body. **Risk of damage.**
- The use of accessory attachments not recommended by Dualit may result in fire, electric shock or injury to persons.
- Do not insert any metallic or sharp utensils into the toaster. **Risk of damage and electric shock.**
- Keep body parts away from moving parts of the appliance. Tie hair back and remove loose clothing or jewellery to avoid them getting caught. **Risk of injury.**
- Never put the appliance or part of it in a dishwasher. **Risk of damage and electric shock.**
- The appliance must not be cleaned by a water jet or steam cleaner. **Risk of burns and scalding.**
- Do not place anything on top or near the sides/underneath of the appliance. **Risk of fire.**
- Remove all packaging before use. **Risk of fire.**

SAVE THESE INSTRUCTIONS

In the interest of improving products, Dualit Ltd. reserves the right to change the product specification without prior notice. All illustrations are for representation only, your model may vary from illustrations shown.



INSTRUCTIONS ON ENVIRONMENT PROTECTION

Do not dispose of this product in the usual household garbage at the end of its life cycle. Please hand it over to a collection point for the recycling of electrical and electronic appliances. The symbol on the product, the instruction of use or the packaging will inform you about the methods of disposal. The materials are recyclable as mentioned on its marking. By recycling, material recycling or other forms of re-utilization of old appliances you are making an important contribution

to protect our environment. Please enquire at the community administration for the authorised disposal location.

IMPORTANT: BEFORE FIRST USE

- Read this instruction manual before you start using the appliance. It gives you important safety information and will ensure you get the most out of your Dualit product.
- Make sure all people associated with the appliance's use understand the operation and safety before they use the unit.
- Keep this manual and your proof of purchase in a safe place.
- Don't forget to register your product at www.dualit.com/register
- When you turn the appliance on for the first time, a "new" smell may be given off; this will dissipate after a few uses.
- Unpack the box with care, keeping all the packaging materials until you are satisfied everything is present and in working order. Once satisfied recycle the packaging appropriately.



DONT FORGET TO REGISTER YOUR PRODUCT

www.dualit.com/register | BY POST 

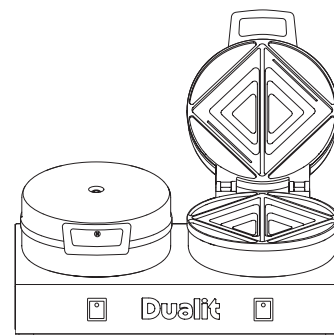

KNOW YOUR TOASTIE MAKER

The hardworking stainless steel Contact Toaster makes delicious toasted sealed triangle sandwiches.

The machine is made from satin finish, top grade stainless steel and each plate is coated with two layers of non-stick coating.

The Hotplates can be turned on individually for greater economy.

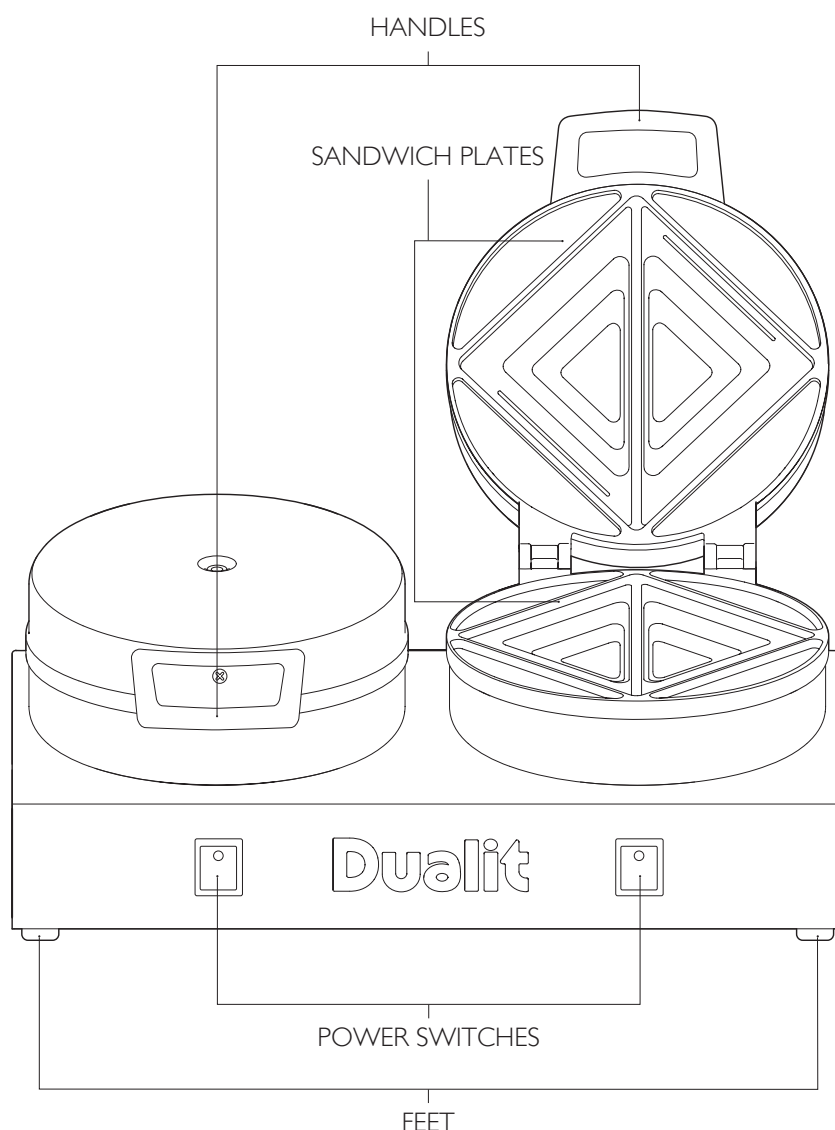

OPERATING INSTRUCTIONS

1. Before use remove screws on handle clamp, and fit plastic handle over clamp and screw on tightly.
2. Both sets of plates can be switched on and off independently.
3. Pre-heat Sandwich Plates for 8 minutes.
4. Lightly butter the **OUTSIDE** of the bread.
5. Place choice of fillings between **UNBUTTERED INSIDE** of the sandwich.
6. Close lid and compress sandwich for 10 seconds.
7. Leave between plates for 70-90 seconds depending on the filling.
8. Lift the lid and remove the toastie with plastic tongs or a spatula. **NEVER USE METAL UTENSILS.**
9. It is imperative that the Sandwich Plates are wiped over with a damp cloth after each use to prevent carbon build-up.
10. After each day's use, allow to cool. Use a **NYLON BRUSH** and clean **ALL** signs of grease off the plates and then wipe over with a clean damp cloth.
11. Never immerse the toastie maker in water. **Risk of electric shock and fire.**
12. Shut off power when not in use and disconnect from wall socket.

DAILY CLEANING

Ensure that the waffle maker is disconnected from the electricity supply and allowed to cool to room temperature before attempting any cleaning.

Use a damp soapy cloth and **NYLON BRUSH** to clean **ALL** signs of grease off the plates and then wipe clean with a damp cloth.

Lightly oil the plates for a few uses after cleaning.

IT IS IMPERATIVE THAT THE CLEANING INSTRUCTIONS ARE COMPLIED WITH.

GUARANTEE

In the unlikely event of a fault with your Dualit waffle maker, providing it is within one year from date of purchase, please contact the place of purchase or Dualit customer services on +44 (0)1293 652 500 for further information. Keep your receipt safe, as you will require this as proof of purchase.